

USER'S GUIDE

Vaisala INTERCAP® Humidity and Temperature Transmitters HMDW80 Series

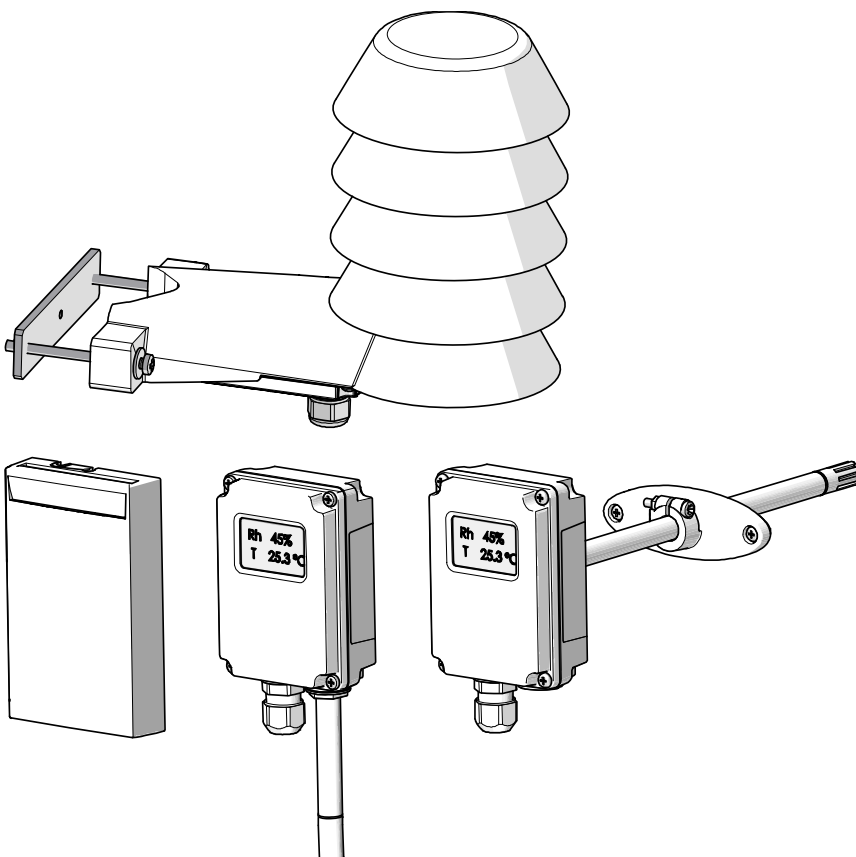

PUBLISHED BY

Vaisala Oyj

Street address: Vanha Nurmijärventie 21, FI-01670 Vantaa, Finland

Mailing address: P.O. Box 26, FI-00421 Helsinki, Finland

Phone: +358 9 8949 1

Fax: +358 9 8949 2227

Visit our Internet pages at www.vaisala.com.

© Vaisala 2016

No part of this manual may be reproduced, published or publicly displayed in any form or by any means, electronic or mechanical (including photocopying), nor may its contents be modified, translated, adapted, sold or disclosed to a third party without prior written permission of the copyright holder. Translated manuals and translated portions of multilingual documents are based on the original English versions. In ambiguous cases, the English versions are applicable, not the translations.

The contents of this manual are subject to change without prior notice.

Local rules and regulations may vary and they shall take precedence over the information contained in this manual. Vaisala makes no representations on this manual's compliance with the local rules and regulations applicable at any given time, and hereby disclaims any and all responsibilities related thereto.

This manual does not create any legally binding obligations for Vaisala towards customers or end users. All legally binding obligations and agreements are included exclusively in the applicable supply contract or the General Conditions of Sale and General Conditions of Service of Vaisala.

Table of Contents

CHAPTER 1

GENERAL INFORMATION	5
About This Manual	5
Contents of This Manual	5
Version Information	6
Related Manuals	6
Documentation Conventions	7
Safety	7
ESD Protection.....	7
Recycling	8
Regulatory Compliances	8
Trademarks	8
Software License	8
Warranty	9

CHAPTER 2

PRODUCT OVERVIEW	10
Introduction to HMDW80 Series	10
HMDW80 Series Transmitter Models	11
Output Parameters Explained	11
Transmitter Parts – Duct Models	12
Transmitter Parts – Wall Models	13
Transmitter Parts – Outdoor Models	15
Display	16
Analog Output Overrange Behavior	17

CHAPTER 3

INSTALLATION	18
Selecting Location	18
Installing Duct Models HMD82/83 and TMD82/83	19
Installing Wall Models HMW88, HMW89 and TMW88	21
Installing Wall Models HMW82/82P100/83 and TMW82/83	22
Installing Outdoor Models HMS82/83, TMS82	23
Configuration and Wiring.....	24
Pole installation	25
Wall installation	26
Wiring	27
HMD82(D), HMW88(D), and HMS82	27
TMS82	28
TMD82.....	28
TMD83.....	28
HMW82	29
HMW82P100	29
TMW82.....	29

HMW83.....	30
TMW83.....	30
DIP Switches	31
CHAPTER 4	
MAINTENANCE.....	33
Cleaning.....	33
Calibration	33
Replacing the INTERCAP® Humidity Sensor	34
Replacing the INTERCAP® Sensor on Models HMD82/83 and HMW88/89.....	34
Replacing the INTERCAP® Sensor on Wall Models HMW82/82P100/83	35
Replacing the INTERCAP® Sensor on Outdoor Models HMS82/83.....	36
CHAPTER 5	
TROUBLESHOOTING.....	40
Problem Situations	40
Analog Output Error State	41
Error Messages on the Display	41
Technical Support	42
CHAPTER 6	
TECHNICAL DATA	43
Specifications	43
Spare Parts and Accessories	47

List of Figures

Figure 1	Parts of Duct Mounted Models (HMD82/83 and TMD82/83) ...	12
Figure 2	Parts of Wall Mounted Models (HMW88/89, TMW88)	13
Figure 3	Parts of Wall Mounted Models (HMW82/82P100/83 and TMW82/83).....	14
Figure 4	Parts of Outdoor Models (HMS82/83, TMS82)	15
Figure 5	Startup Screens (HMD83D)	16
Figure 6	Measurement Screen (HMD83D).....	16
Figure 7	Measurement Screen with Error (HMD83D)	16
Figure 8	Duct Model Installation	20
Figure 9	Position the Sensor to Center of Duct.....	20
Figure 10	Duct Model Dimensions (HMD82/83 and TMD82/83).....	20
Figure 11	Wall Model Dimensions (HMW88/89, TMW88).....	21
Figure 12	Wall Model Dimensions (HMW82/82P100/83 and TMW82/83).....	22
Figure 13	Outdoor Model Dimensions (HMS82/83, TMS82)	23
Figure 14	Location of DIP Switches and Screw Terminal	24
Figure 15	HMS82/83 Pole Installation	25
Figure 16	Securing the Cable on a Pole	25
Figure 17	HMS82/83 Wall Installation	26
Figure 18	Securing the Cable on a Wall.....	26
Figure 19	DIP Switches on Component Board.....	31
Figure 20	Sensors on HMD82/83 and HMW88/89 Models	34
Figure 21	INTERCAP [®] Sensor on HMW82/83 Models	35
Figure 22	Unplugging the Screw Terminal	36
Figure 23	Opening the Radiation Shield Screws.....	37
Figure 24	Removing the Radiation Shield Screws	37
Figure 25	Location of Locking Tab	38
Figure 26	Removing the Radiation Shield.....	38
Figure 27	Filter Removed	39
Figure 28	Sensors on HMS82/83 Models	39

List of Tables

Table 1	Manual Revisions	6
Table 2	Related Manuals	6
Table 3	HMDW80 Series Transmitter Models.....	11
Table 4	Parameters Supported by HMDW80 Series	11
Table 5	DIP Switch Positions for Metric Output	32
Table 6	DIP Switch Positions for Non-Metric Output	32
Table 7	Possible Problem Situations and Their Remedies.....	40
Table 8	Error Messages on the Display	41
Table 9	Specifications for Models HMW82/83/HMW82P100 and TMW82/83.....	43
Table 10	Specifications for Models HMD82/83, TMD82/83, HMW88/89, HMS82/83, and TMS82.....	44
Table 11	Specifications for Models HMD82/83D, HMW88/89D, and TMW88.....	45
Table 12	Operating Environment (All Models)	46
Table 13	Inputs and Outputs	46
Table 14	Mechanics	46
Table 15	HMDW80 Series Spare Parts and Accessories	47

CHAPTER 1

GENERAL INFORMATION

This chapter provides general notes for the manual and the HMDW80 series.

About This Manual

This manual provides information for installing, operating, and maintaining HMDW80 series transmitters.

Contents of This Manual

This manual consists of the following chapters:

- Chapter 1, General Information, provides general notes for the manual and the HMDW80 series.
- Chapter 2, Product Overview, introduces the features and options of the HMDW80 series transmitters.
- Chapter 3, Installation, provides you with information that is intended to help you install HMDW80 series transmitters.
- Chapter 4, Maintenance, provides information that is needed in basic maintenance of HMDW80 series.
- Chapter 5, Troubleshooting, describes possible problems, their probable causes and remedies, and provides contact information for technical support.
- Chapter 6, Technical Data, provides the technical data of the HMDW80 series.

Version Information

Table 1 **Manual Revisions**

Manual Code	Description
M211510EN-E	<p>May 2016. This manual. Changes:</p> <ul style="list-style-type: none"> - Added transmitter models TMS82, TMW88, and HMW82P100. - Updated the HMD82(D)/HMW88(D)/HMS82 wiring diagram for one power supply alternative. - Updated the HMD82(D), HMW88(D), HMS82, and TMD82 power supply requirements information in wiring diagrams.
M211510EN-D	<p>March 2015. Previous version. Changes:</p> <ul style="list-style-type: none"> - Updated wiring information for models HMD82(D), HMW88(D), and HMS82. - Updated troubleshooting instructions. - Updated technical specification: accuracy of calculated parameters and current consumption of voltage output models. - Updated list of spare parts and accessories.
M211510EN-C	<p>June 2013. Changes:</p> <ul style="list-style-type: none"> - Added outdoor transmitter models HMS82 and HMS83. - Changed PTFE membrane filter model from 230727SP (30 mm long) to ASM210856SP (24.5 mm long). - Changed PTFE filter model from 219452SP (40 mm long) to DRW239993SP (22 mm long). - Improved IP classification of models with display to IP65.

Related Manuals

Table 2 **Related Manuals**

Manual Code	Manual Name
M211507EN	HMD82 HMD83 Wiring Diagram
M211508EN	HMW88 HMW89 TMW88 Wiring Diagram
M211328EN	HMW82 HMW83 Quick Guide
M211509EN	HMS82 HMS83 TMS82 Quick Guide

Documentation Conventions

Throughout the manual, important safety considerations are highlighted as follows:

WARNING

Warning alerts you to a serious hazard. If you do not read and follow instructions very carefully at this point, there is a risk of injury or even death.

CAUTION

Caution warns you of a potential hazard. If you do not read and follow instructions carefully at this point, the product could be damaged or important data could be lost.

NOTE

Note highlights important information on using the product.

Safety

The HMDW80 series transmitter delivered to you has been tested for safety and approved as shipped from the factory. Note the following precautions:

WARNING

Installation of HMDW80 series transmitters may involve working at a height. Assess the risks and plan your work so it is carried out safely. Try avoiding work at height, if you can.

CAUTION

Make sure the wires are de-energized when you connect them to the screw terminals.

CAUTION

Do not modify the unit. Improper modification can damage the product or lead to malfunction.

ESD Protection

Electrostatic Discharge (ESD) can cause immediate or latent damage to electronic circuits. Vaisala products are adequately protected against ESD for their intended use. It is possible to damage the product, however, by delivering electrostatic discharges when touching, removing, or inserting any objects inside the equipment housing.

To make sure you are not delivering high static voltages yourself, always hold component boards by the edges and avoid touching the component contacts.

Recycling



Recycle all applicable material.



Dispose of the unit according to statutory regulations. Do not dispose of with regular household refuse.

Regulatory Compliances

HMDW80 series complies with the following performance and environmental test standards:

- EMC-Directive

Conformity is shown by compliance with the following standards:

- EN 61326-1: Electrical equipment for measurement, control, and laboratory use – EMC requirements – For use in industrial locations.
- EN 550022: Information technology equipment – Radio disturbance characteristics – Limits and methods of measurement.



Trademarks

INTERCAP[®] is a registered trademark of Vaisala Oyj.

Software License

This product contains software developed by Vaisala. Use of the software is governed by license terms and conditions included in the applicable supply contract or, in the absence of separate license terms and conditions, by the General License Conditions of Vaisala Group.

Warranty

Visit our Internet pages for standard warranty terms and conditions:
www.vaisala.com/warranty.

Please observe that any such warranty may not be valid in case of damage due to normal wear and tear, exceptional operating conditions, negligent handling or installation, or unauthorized modifications. Please see the applicable supply contract or Conditions of Sale for details of the warranty for each product.

CHAPTER 2

PRODUCT OVERVIEW

This chapter introduces the features and options of the HMDW80 series transmitters.

Introduction to HMDW80 Series

Vaisala INTERCAP[®] Humidity and Temperature Transmitter Series HMDW80 measure relative humidity and temperature in various building automation applications. Transmitters combine easy installation and reliable operation with a low requirement for maintenance.

HMDW80 series includes transmitters for wall and duct mounting, humid areas, and for outdoor installation. It also includes temperature-only transmitters and transmitters with an optional display. Calculated humidity parameters – dewpoint, wet bulb temperature, and enthalpy – are also available.

HMDW80 series transmitters require minimal maintenance thanks to their excellent sensor stability and high-quality materials. If necessary, the INTERCAP[®] humidity sensor can be easily exchanged in the field with practically no downtime.

Features provided by transmitters in the HMDW80 series:

- ± 3.0 %RH accuracy.
- 0 ... 100 %RH measurement range.
- User exchangeable INTERCAP[®] humidity sensor for easy field replacement.
- Several output parameters; see HMDW80 Series Transmitter Models on page 11 for list of supported parameters by transmitter model.
- Several IP65-classified models for demanding HVAC applications.
- UL-V0 flammability rating.

HMDW80 Series Transmitter Models

Table 3 below lists the most important differences between the HMDW80 series transmitter models. For technical specifications, see Chapter 6, Technical Data, on page 43.

Table 3 HMDW80 Series Transmitter Models

Model	Type	Outputs	Display	IP Rating	Output Parameters
HMD82	Duct	2 x 4 ... 20 mA	No	IP65	T, RH, Td, h, Tw
HMD82D	Duct	2 x 4 ... 20 mA	Yes	IP65	T, RH, Td, h, Tw
TMD82	Duct	1 x 4 ... 20 mA	No	IP65	T
HMD83	Duct	2 x 0 ... 10 V	No	IP65	T, RH, Td, h, Tw
HMD83D	Duct	2 x 0 ... 10 V	Yes	IP65	T, RH, Td, h, Tw
TMD83	Duct	1 x 0 ... 10 V	No	IP65	T
HMW82	Wall	2 x 4 ... 20 mA	No	IP30	T, RH
HMW82P100	Wall	2 x 4 ... 20 mA	No	IP30	T, RH
TMW82	Wall	1 x 4 ... 20 mA	No	IP30	T
HMW83	Wall	2 x 0 ... 10 V	No	IP30	T, RH
TMW83	Wall	1 x 0 ... 10 V	No	IP30	T
HMW88	Wall	2 x 4 ... 20 mA	No	IP65	T, RH, Td, h, Tw
HMW88D	Wall	2 x 4 ... 20 mA	Yes	IP65	T, RH, Td, h, Tw
HMW89	Wall	2 x 0 ... 10 V	No	IP65	T, RH, Td, h, Tw
TMW88	Wall	1 x 4 ... 20 mA	No	IP65	T
HMW89D	Wall	2 x 0 ... 10 V	Yes	IP65	T, RH, Td, h, Tw
HMS82	Outdoor	2 x 4 ... 20 mA	No	IP65	T, RH, Td, h, Tw
HMS83	Outdoor	2 x 0 ... 10 V	No	IP65	T, RH, Td, h, Tw
TMS82	Outdoor	1 x 4 ... 20 mA	No	IP65	T

Output Parameters Explained

Table 4 Parameters Supported by HMDW80 Series

Parameter	Symbol	Unit(s)	Description
Temperature	T	°C °F	Temperature in Celsius or Fahrenheit scale.
Relative humidity	RH	%	Ratio of the partial pressure of water vapor in the air to the saturation vapor pressure of air at the current temperature.
Dewpoint	Td	°C °F	Temperature at which the water vapor in the air will condense into water at the current pressure. When the dewpoint is below 0 °C, the transmitter outputs frostpoint (Tf) instead of dewpoint.
Enthalpy	h	kJ/kg BTU/lb	Sum of the internal energy of a thermodynamic system.
Wet bulb temperature	Tw	°C °F	The minimum temperature that can be reached by evaporative cooling in the current conditions.

Transmitter Parts – Duct Models

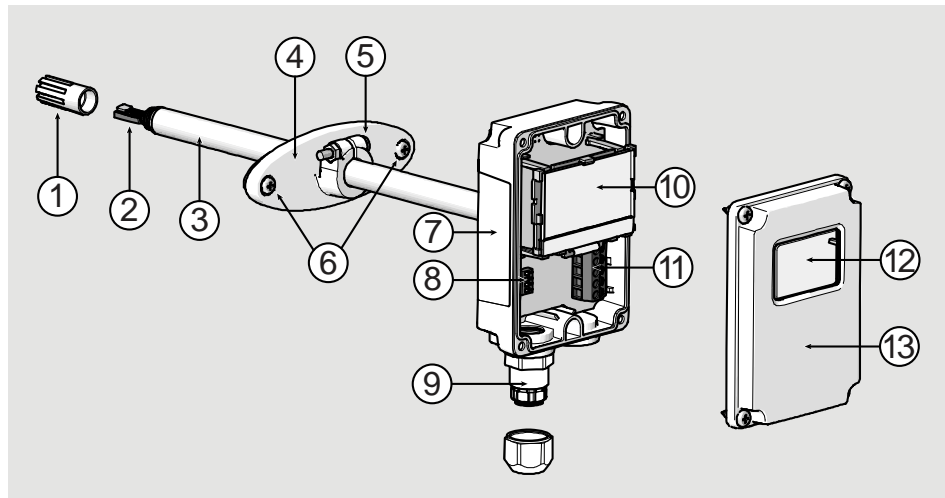

1302-018

Figure 1 Parts of Duct Mounted Models (HMD82/83 and TMD82/83)

- 1 = PTFE membrane filter (spare part item ASM210856SP).
- 2 = INTERCAP[®] humidity sensor and temperature sensor.
Not included in TMD82 and TMD83 models.
- 3 = Probe.
- 4 = Fastening flange.
- 5 = Tightening screw for fastening flange.
- 6 = Screws for attaching the flange to a duct (2 pcs included).
- 7 = Type label.
- 8 = DIP switches for selecting humidity parameter and display units.
Not included in TMD82 and TMD83 models.
- 9 = Cable gland. Suitable for 4 ... 8 mm diameter cable.
- 10 = Display (in HMD82D and HMD83D models).
- 11 = Screw terminals.
- 12 = Window for display (in HMD82D and HMD83D models).
- 13 = Transmitter cover with captive screws.

Transmitter Parts – Wall Models

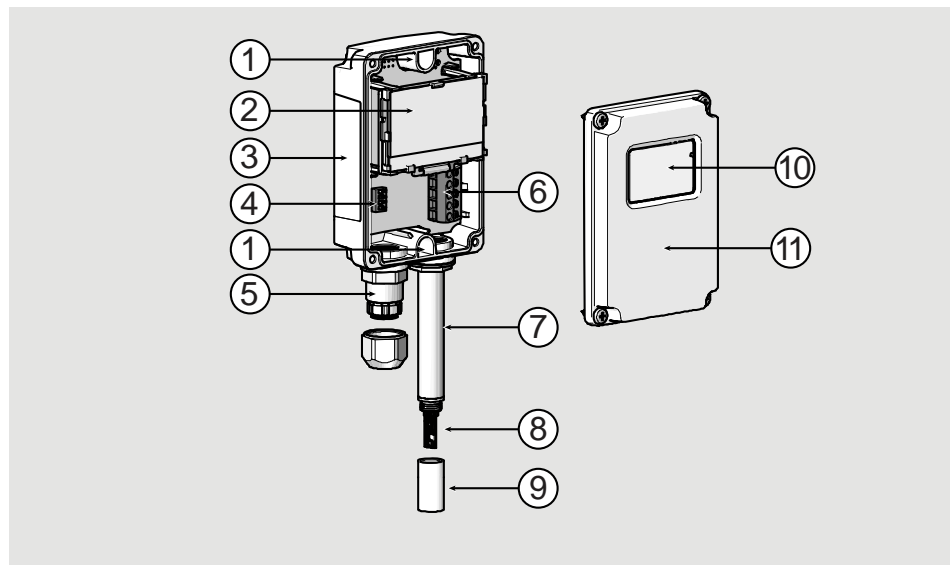

1302-019

Figure 2 Parts of Wall Mounted Models (HMW88/89, TMW88)

- 1 = Screw holes for mounting (2 pcs).
- 2 = Display (in HMW88D and HMW89D models).
- 3 = Type label.
- 4 = DIP switches for selecting humidity parameter and display units
- 5 = Cable gland. Suitable for 4 ... 8 mm diameter cable.
- 6 = Screw terminals.
- 7 = Probe.
- 8 = INTERCAP[®] humidity sensor and temperature sensor.
- 9 = PTFE filter (spare part item DRW239993SP).
- 10 = Window for display (in HMW88D and HMW89D models)
- 11 = Transmitter cover with captive screws.

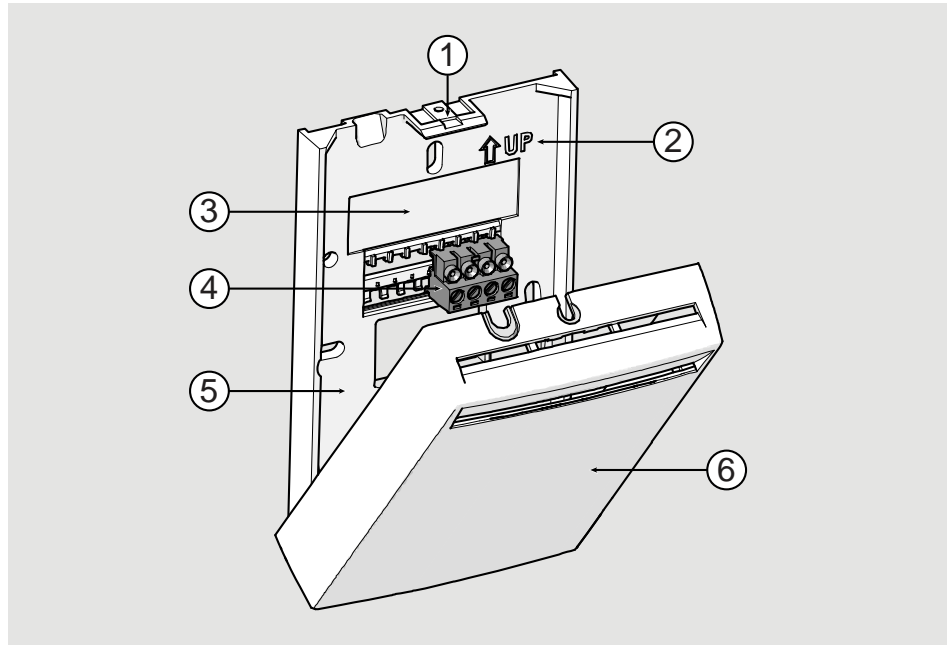

1302-020

Figure 3 **Parts of Wall Mounted Models (HMW82/82P100/83 and TMW82/83)**

- 1 = Opening tab: push down to open the transmitter.
- 2 = Direction arrow. Must point up after mounting base has been installed on the wall.
- 3 = Wiring label.
- 4 = Screw terminals.
- 5 = Mounting base.
- 6 = Transmitter cover with component board.

Transmitter Parts – Outdoor Models

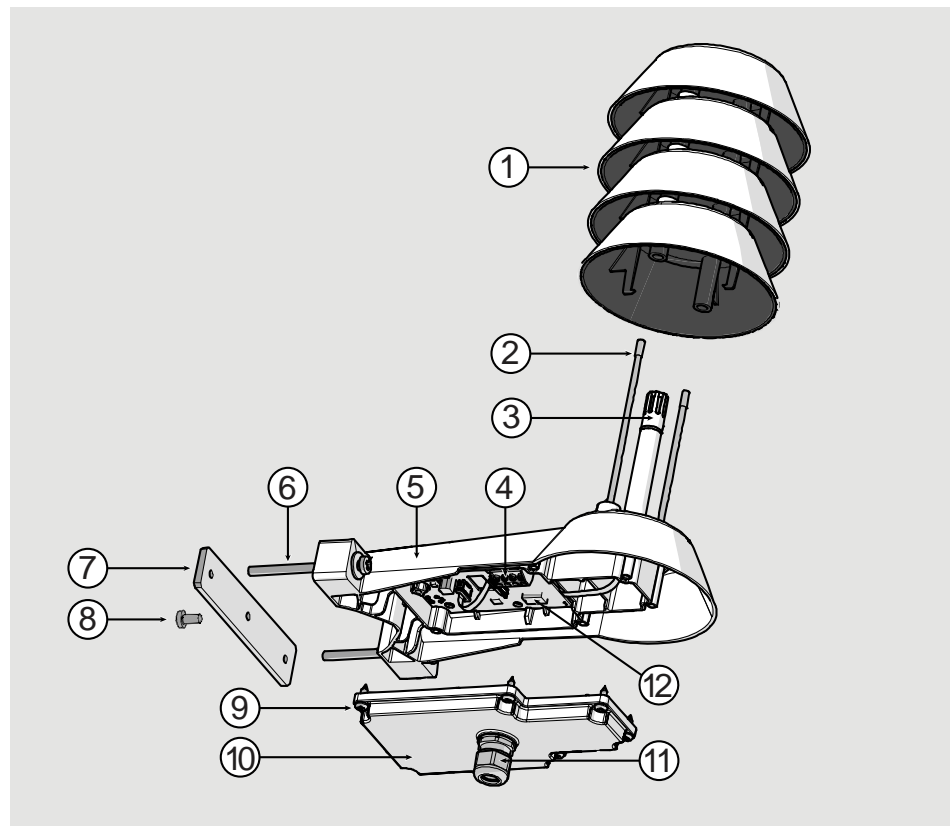

1304-048

Figure 4 Parts of Outdoor Models (HMS82/83, TMS82)

- 1 = Radiation shield. Do not remove for installation, only when changing sensor or filter.
- 2 = Long screws that keep the radiation shield in place (2 pcs), 3 mm hex socket.
- 3 = INTERCAP[®] humidity sensor and temperature sensor under PTFE membrane filter (filter spare part item ASM210856SP).
- 4 = Screw terminal. Detachable for easy installation.
- 5 = Transmitter body.
- 6 = Screws for pole mounting (2 pcs), medium size crosshead type (Pozidriv).
- 7 = Clamp for pole mounting. The holes are threaded for the included pole mounting screws and set screw.
- 8 = Set screw, medium size crosshead type (Pozidriv). Install after pole mounting to stop the transmitter from turning.
- 9 = Medium size crosshead screws (6 pcs) that hold the transmitter cover in place.
- 10 = Transmitter cover.
- 11 = Cable gland. Suitable for 4 ... 8 mm diameter cable.
- 12 = Configuration DIP switches. See section DIP Switches on page 31.

Display

Display is present on the following models:

- HMD82D and HMD83D
- HMW88D and HMW89D

When the transmitter is powered on, it displays a sequence of information screens about the transmitter and its analog outputs. The screens are shown for a few seconds each. Checking the screens on startup is a good way to verify that the transmitter's configuration DIP switches are set correctly.

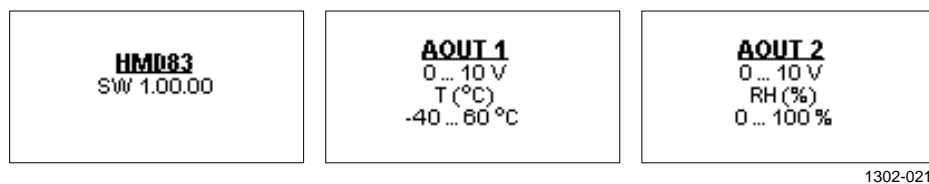

Figure 5 Startup Screens (HMD83D)

After the startup screens have been displayed, the transmitter will show the measurement screen.

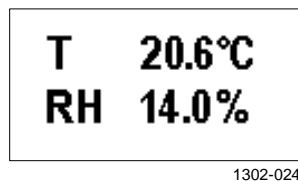

Figure 6 Measurement Screen (HMD83D)

If one of the transmitter's error states is active, a notification symbol and error text will appear on the screen. Depending on the error, the affected measurement readings may be replaced by asterisks “*”. For more information on the possible errors, see section Error Messages on the Display on page 41.



Figure 7 Measurement Screen with Error (HMD83D)

Analog Output Overrange Behavior

Analog outputs of the HMDW80 series transmitters have a defined behavior when the values measured by the transmitter are outside the scaled analog output range:

- Output is clipped at the end of the range.
- Output is set to error state when measured value is 5% outside the scaled range. See section Analog Output Error State on page 41.
- Output resumes normal function when measured value is back on the scaled range.

NOTE

HMW82/83 and TMW82/83 transmitters are different from the rest of the HMDW80 series. Their analog output is clipped at 10% outside the scaled range, and their analog outputs enter the error state when the measured value is 20% outside the range.

For example, consider the temperature output of the HMD82 transmitter. The output is 4 ... 20 mA, scaled to -40 ... +60 °C (-40 ... +140 °F).

- When measured temperature rises above +60 °C (+140 °F), the output rises to 20 mA and stops rising even if temperature rises further.
- If the temperature rises above +65 °C (+149 °F), the output enters the error state of 3.6 mA.

NOTE

This overrange behavior does not mean there is a problem with the measurements, and it does not affect the readings shown on the display (if included in the transmitter model). The display always shows the currently measured readings if the measurement is operating without error. For more information on transmitter errors, see section Error Messages on the Display on page 41.

CHAPTER 3

INSTALLATION

This chapter provides you with information that is intended to help you install HMDW80 series transmitters.

Selecting Location

When mounting duct model transmitters:

- Avoid installing in a location where condensation may fall on the sensor inside the duct.
- Position the sensor in the center of the duct.
- Select a site where the transmitter can be installed horizontally, onto the side of the duct.

When mounting wall model transmitters:

- Select a location that represents well the area of interest.
- Do not install on the ceiling.
- Avoid placing the transmitter near heat and moisture sources, close to the discharge of the supply air ducts, and in direct sunlight.

When mounting outdoor transmitters:

- Install in a place that receives minimal direct sunlight. In the northern hemisphere, the North side of the building typically provides a suitable shaded location.
- Avoid placing the transmitter near windows, air conditioning units, or other heat and moisture sources such as cooling towers.
- Install the transmitter at least 2.5 m above ground level.

Installing Duct Models HMD82/83 and TMD82/83

REQUIRED TOOLS

- Medium size crosshead screwdriver (Pozidriv) for screws on cover and flange.
- Small slotted screwdriver for screw terminals.
- Drill with 2.5 mm and 13 mm bits for making the installation holes.
- Tools for cutting and stripping wires.
- 19 mm open-end wrench for tightening the cable gland.

1. Remove the yellow transport protection cap and separate the fastening flange from the transmitter.
2. Use the flange to mark the location and size of the installation holes on the side of the duct.
3. Drill the installation holes in the duct. Refer to Figure 8 below.
4. Secure the fastening flange to the duct with the two screws (included).
5. Push the probe of the transmitter through the flange and into the duct. The probe should reach far enough so that the sensor is located in the middle of the duct.
6. Secure the transmitter to the flange by tightening the screw on the flange that holds the probe in place.
7. Open the transmitter cover, and route the power and signal cable through the cable gland. Connect the wires to the screw terminals. Refer to section Wiring on page 27.
8. Check that the DIP switches (if present in your transmitter model) are set as desired. See section DIP Switches on page 31.
9. Tighten the cable gland and close the transmitter cover.

Installing Wall Models HMW88, HMW89 and TMW88

REQUIRED TOOLS

- Medium size crosshead screwdriver (Pozidriv) for cover screws.
- Small slotted screwdriver for screw terminals.
- Two installation screws: $\text{Ø} < 3.5 \text{ mm}$, head $\text{Ø} < 10 \text{ mm}$.
- Depending on the wall material and screw type, you may need a drill and a suitable drill bit to make installation holes for screws.
- Tools for cutting and stripping wires.
- 19 mm open-end wrench for tightening the cable gland.

1. Open the transmitter cover and use two screws (not included) to attach the transmitter to the wall. The probe and cable gland should point down.
2. Route the power and signal cable to the screw terminals and connect the wires. Refer to section Wiring on page 27.
3. Close the transmitter cover and remove the yellow transport protection cap from the probe.

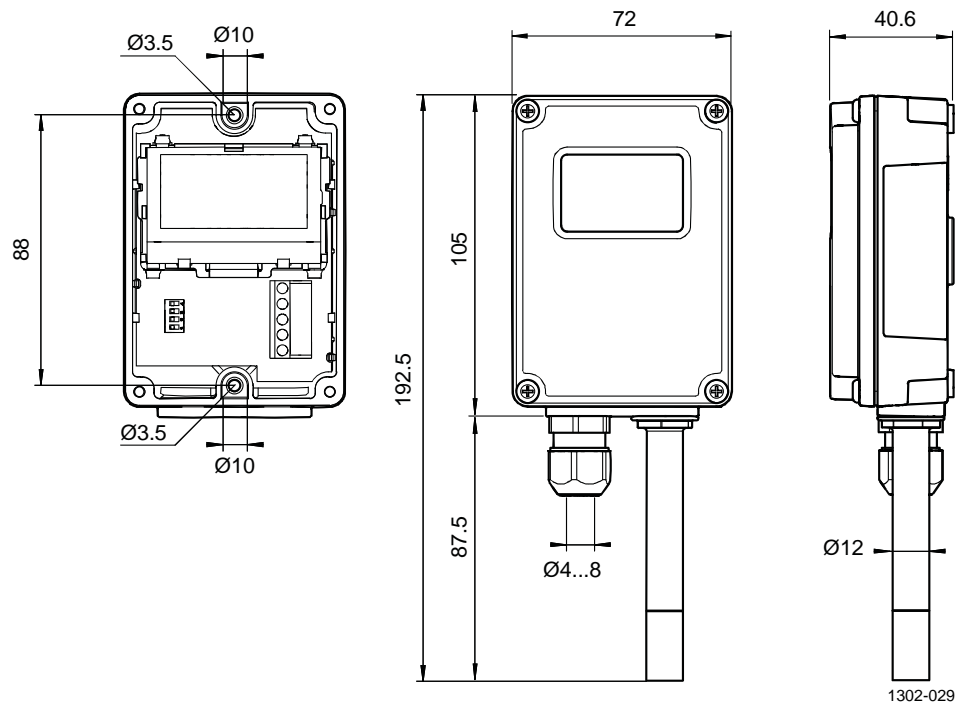

Figure 11 Wall Model Dimensions (HMW88/89, TMW88)

Installing Wall Models HMW82/82P100/83 and TMW82/83

REQUIRED TOOLS

- Small flat head screwdriver for opening the transmitter and for screw terminals.
- Two screws, max Ø 4 mm.
- Depending on the wall material and screw type, you may need a drill and a suitable drill bit to make installation holes for screws.
- Tools for cutting and stripping wires.

1. Use a flat head screwdriver to push down the tab on top of the transmitter and separate the mounting base from the transmitter cover.
2. Use the mounting holes to attach the mounting base securely. Use at least two screws (not included, max Ø 4 mm).

NOTE

The arrow on the mounting base must point straight up after installation. Proper orientation is important: air must flow through the vents on the bottom and top.

3. Route the power and signal cable to the screw terminals and connect the wires. Refer to section Wiring on page 27.
4. Close the transmitter cover when done.

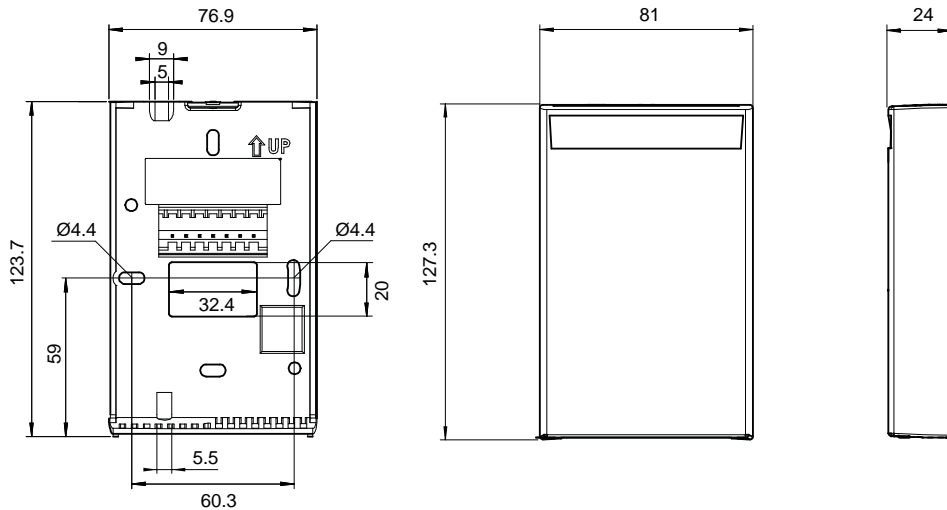

1302-030

Figure 12 Wall Model Dimensions (HMW82/82P100/83 and TMW82/83)

Installing Outdoor Models HMS82/83, TMS82

WARNING

Assess the risks posed by the height and accessibility of the installation location, and plan your work so it is carried out safely. Try avoiding work at height, if you can.

REQUIRED TOOLS

- Medium size crosshead screwdriver (Pozidriv)
- Small slotted screwdriver for screw terminals.
- Tools for cutting and stripping wires.
- 19 mm open-end wrench for tightening the cable gland.

Additional tools for pole installation:

- Zip ties for securing the cable to the pole.

Additional tools for wall installation:

- Drill and bits.
- Screws (2 pcs, $\text{Ø} < 5.5 \text{ mm}$) and wall plugs
- Cable clips for securing the cable to the wall.

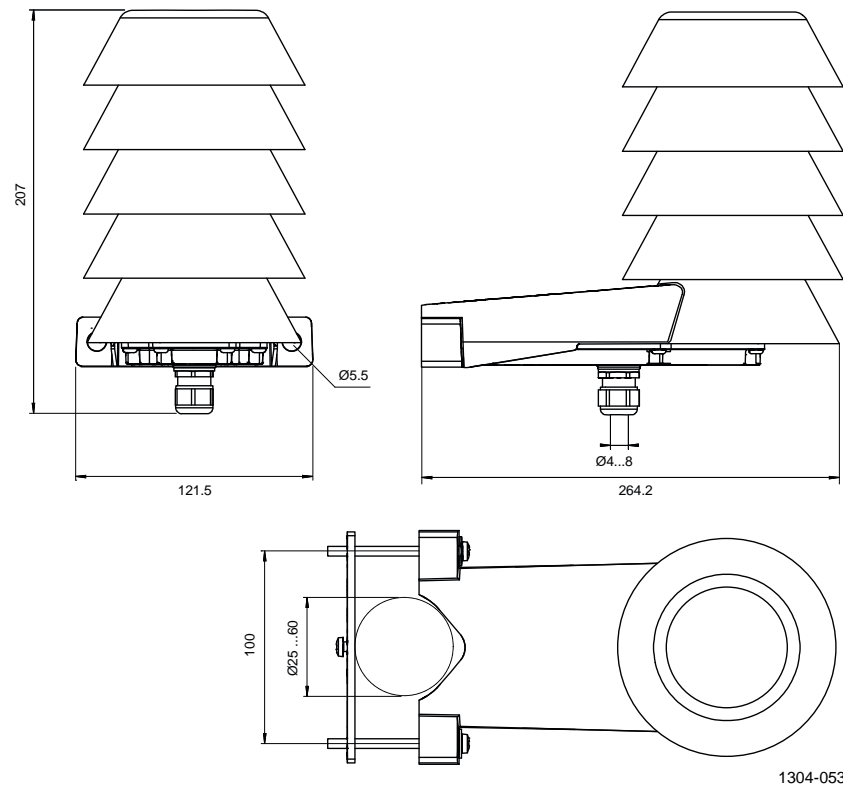
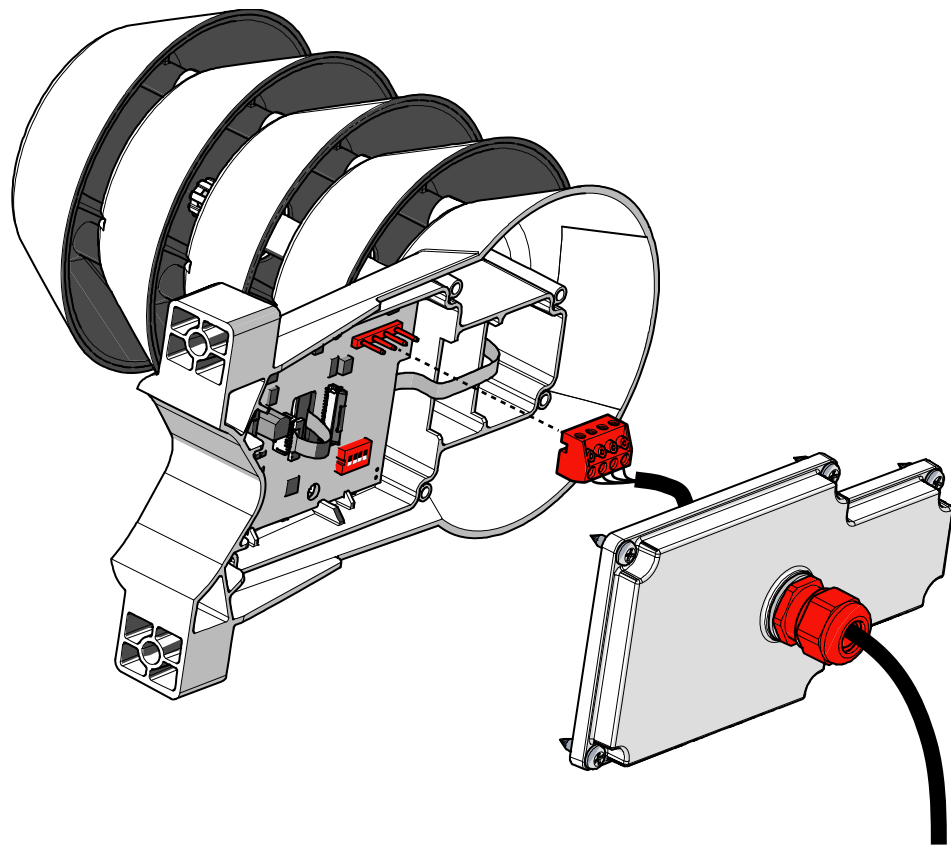

Figure 13 Outdoor Model Dimensions (HMS82/83, TMS82)

Configuration and Wiring

To minimize working at height at the installation location, prepare the transmitter configuration and wiring before climbing up.

1. Open the six screws that hold the transmitter cover.
2. Check that the DIP switches are set as desired. See section DIP Switches on page 31.
3. Route the power and signal cable to the screw terminals and connect the wires. Refer to section Wiring on page 27.
4. Disconnect the screw terminal block by pulling it away from the component board.
5. Adjust the length of cable between the cable gland and the terminal block. Make the cable short enough to close the cover without leaving a cable loop in the transmitter.
6. Tighten the cable gland. Leave the cover off for now.



1304-059

Figure 14 Location of DIP Switches and Screw Terminal

Pole installation

NOTE

Recommended pole diameter for HMS82/83/TMS82 installation with the supplied clamp and screws is 25 ... 60 mm.

1. Use the supplied clamp and screws to mount the transmitter on a pole.
2. To prevent the transmitter from turning on the pole, tighten the set screw on the center hole of the clamp.

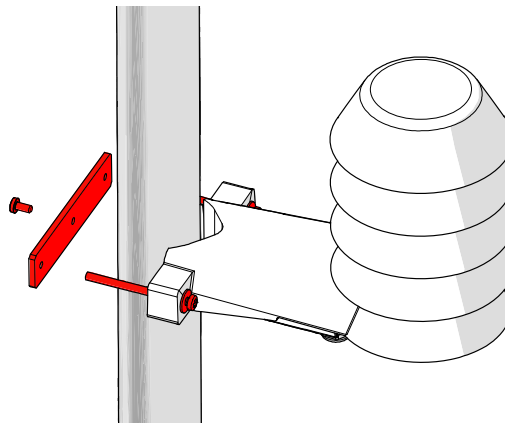

Figure 15 HMS82/83 Pole Installation

3. Plug in the screw terminal block, close the cover, and tighten the screws.
4. Secure the cable to the pole using a zip tie. Allow some cable to hang down from the cable gland to prevent water from entering the transmitter along the cable.

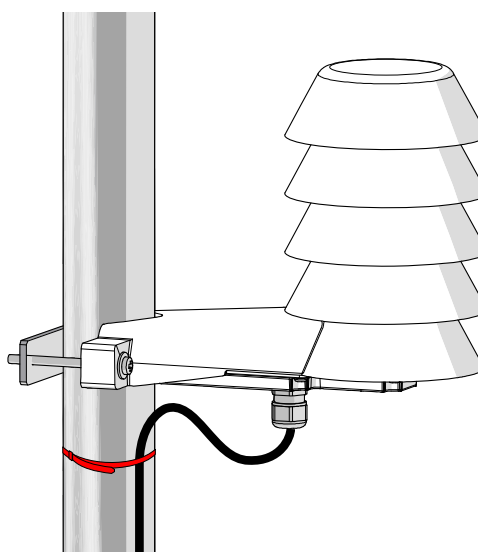

Figure 16 Securing the Cable on a Pole

Wall installation

1. Drill two holes for wall plugs 100 mm apart.
2. Place the wall plugs in the holes.
3. Mount the transmitter using two screws of sufficient length.

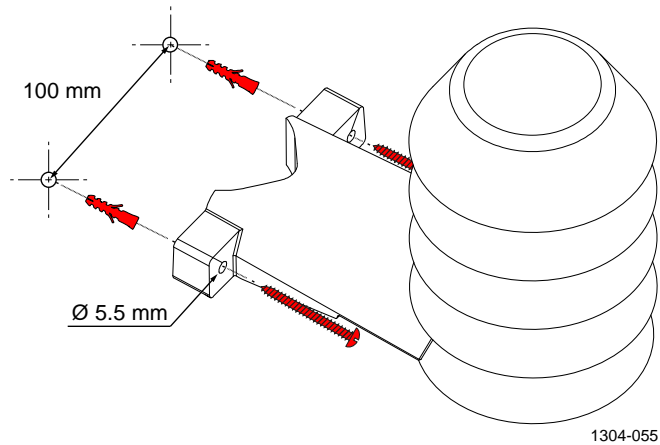

Figure 17 HMS82/83 Wall Installation

4. Plug in the screw terminal block, close the cover, and tighten the screws.
5. Secure the cable to the wall using cable ties. Allow some cable to hang down from the cable gland to prevent water from running to the transmitter along the cable.

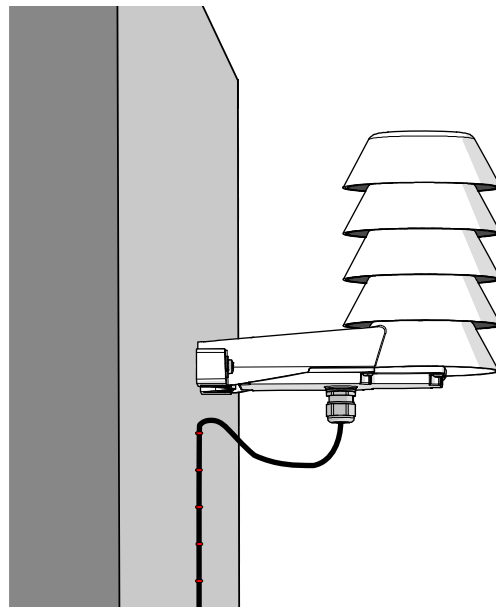

Figure 18 Securing the Cable on a Wall

Wiring

WARNING Connect only de-energized wires.

NOTE

Transmitters with a configurable humidity output parameter use the marking **HUM** on the screw terminal labels. The default output parameter is relative humidity (RH) with output scaled to 0 ... 100 %RH, but the parameter can be changed using DIP switches. Changing the parameter also changes the output scaling. See section DIP Switches on page 31.

HMD82(D), HMW88(D), and HMS82

Two 4 ... 20 mA
outputs, temperature
output scaling
-40 ... +60 °C
(-40 ... +140 °F).

You must connect the HUM channel even if you only want to measure temperature. Connecting the T channel is optional.

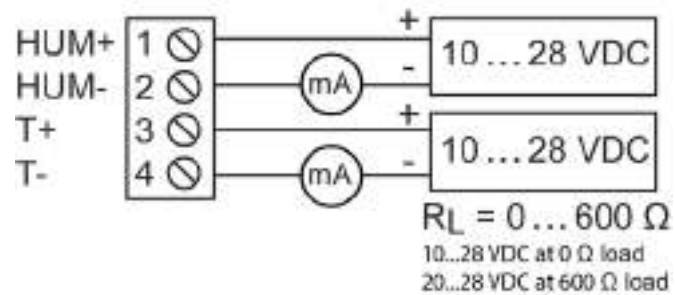

Alternate wiring with one power supply.

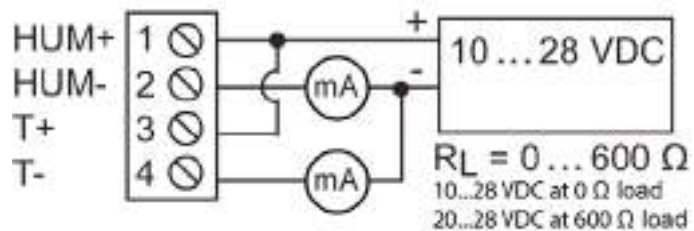

TMS82

4 ... 20 mA output,
scaling -40 ... +60 °C
(-40 ... +140 °F).

Leave terminals 3 and 4
unconnected.

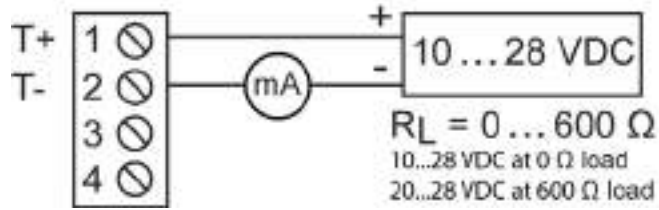

TMD82

4 ... 20 mA output,
scaling -40 ... +60 °C
(-40 ... +140 °F).

Leave terminals 3 and 4
unconnected.

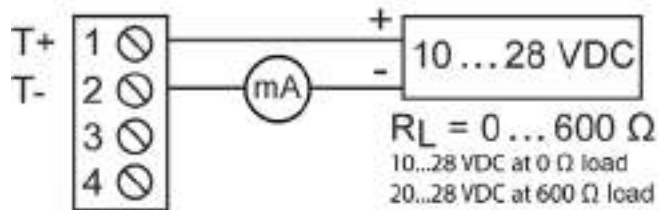

TMD83

One 0 ... 10 V output,
scaling -40 ... +60 °C
(-40 ... +140 °F).

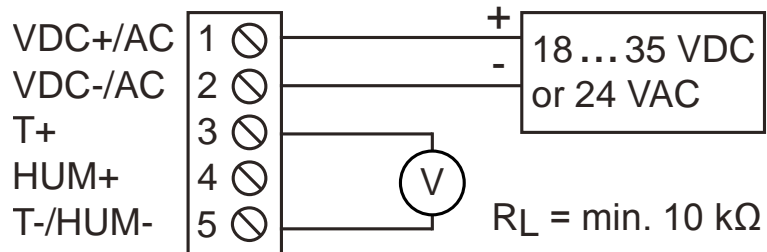

Terminals 2 and 5 are
internally connected on
the transmitter, so you
can also use a cable with
three wires.

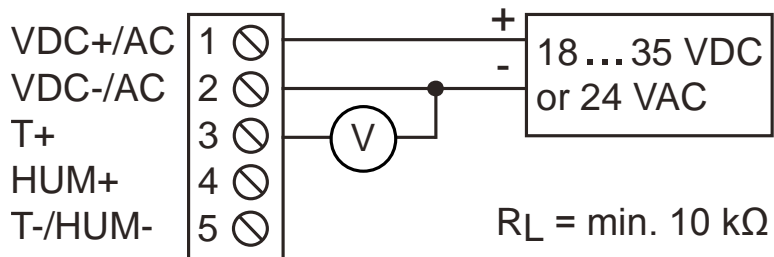

HMW82

Two 4 ... 20 mA outputs, temperature output scaling
-5 ... +55 °C
(+23 ... +131 °F).

You must connect the RH channel of the HMW82, even if you only want to measure temperature. Connecting the T channel is optional.

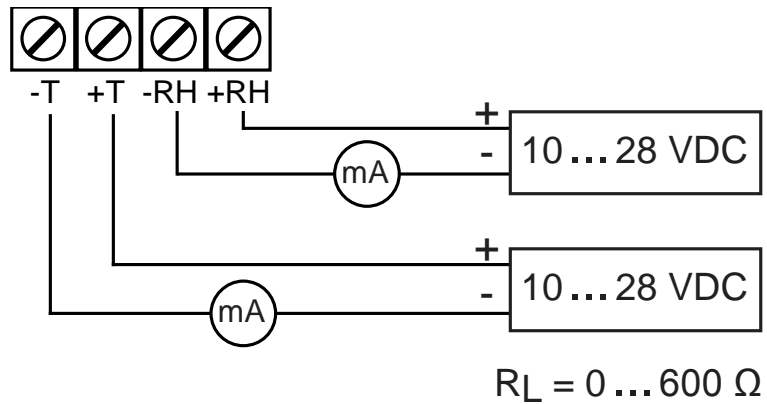

HMW82P100

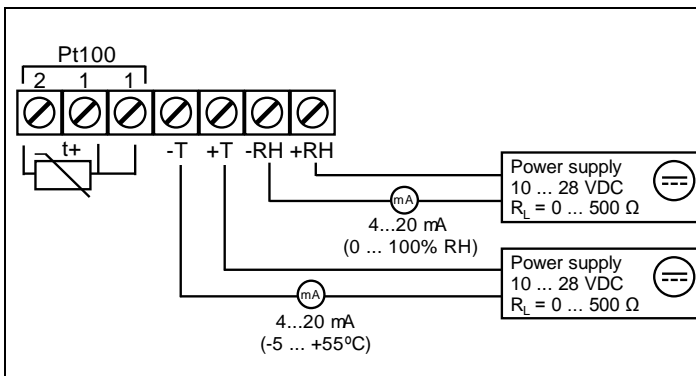

HMW82P100

Includes a passive Pt100 temperature sensor (Class F 0.1 IEC 60751) with a 3-wire connection.

TMW82

One 4 ... 20 mA output, scaling -5 ... +55 °C
(+23 ... +131 °F).

Leave the two terminals on the left unconnected.

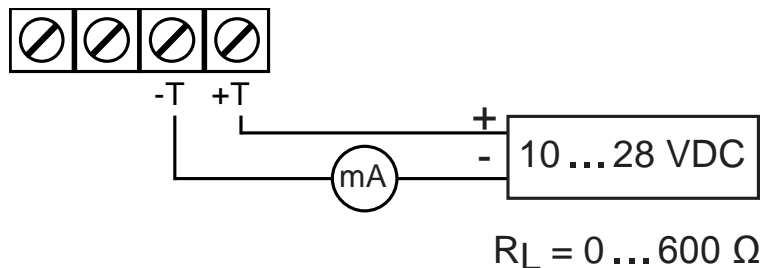

HMW83

Two 0 ... 10 V outputs,
temperature output
scaling -5 ... +55 °C
(+23 ... +131 °F).

This is the
recommended wiring
for long cables.

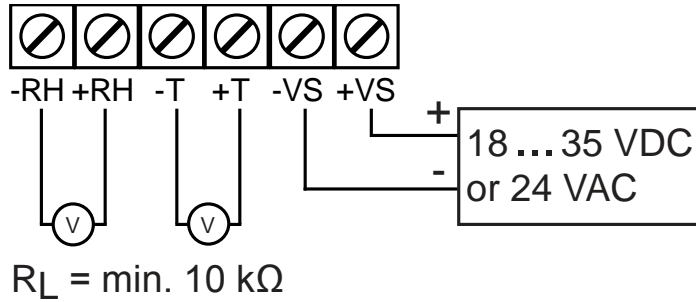

3-wire connection with -
VS as common ground.
Not recommended if
cable resistance is more
than 2.5 Ω.

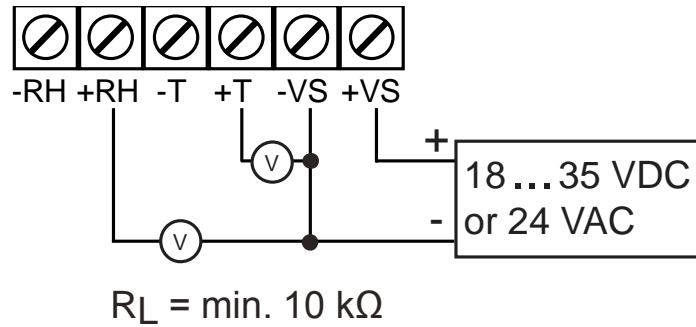

TMW83

One 0 ... 10 V output,
scaling -5 ... +55 °C
(+23 ... +131 °F).

This is the
recommended wiring
for long cables.

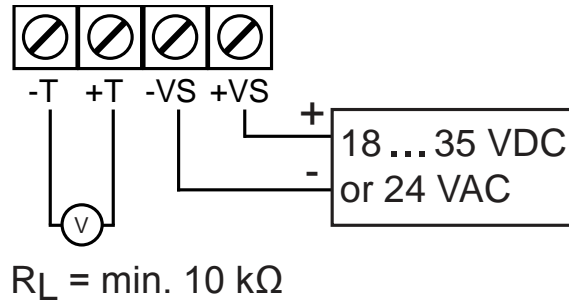

3-wire connection with
-VS as common ground.
Not recommended if
cable resistance is more
than 2.5 Ω.

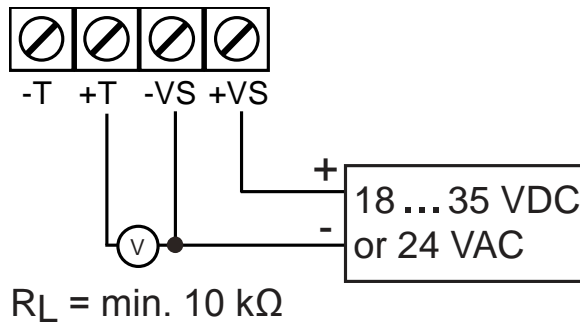

DIP Switches

The DIP switches on the component board control the humidity output parameter and scaling, and the units that are shown on the display. The switches are present on the following models:

- HMD82(D) and HMD83(D)
- HMW88(D) and HMW89(D)
- HMS82 and HMS83

Figure 19 below shows the default position of the DIP switches. The default settings are:

- Metric units shown on display.
- Relative humidity (RH) selected as humidity output parameter.

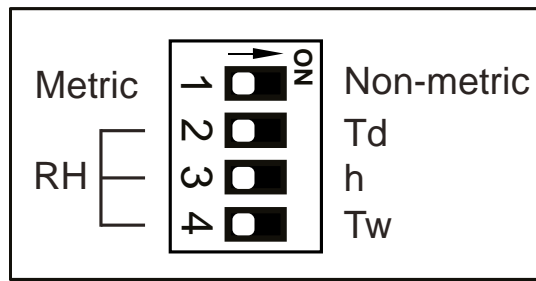

1302-053

Figure 19 **DIP Switches on Component Board**

Table 5 DIP Switch Positions for Metric Output

DIP Position	Analog Output Parameter and Scaling	Parameters and Units on Display
	Relative humidity (RH) 0 ... 100 % Temperature (T) -40 ... +60 °C	RH (%) T (°C)
	Dewpoint (Td) -40 ... +60 °C Temperature (T) -40 ... +60 °C	Td (°C) T (°C)
	Enthalpy (h) -40 ... +460 kJ/kg Temperature (T) -40 ... +60 °C	h (kJ/kg) T (°C)
	Wet bulb temperature (Tw) -40 ... +60 °C Temperature (T) -40 ... +60 °C	Tw (°C) T (°C)

Table 6 DIP Switch Positions for Non-Metric Output

DIP Position	Analog Output Parameter and Scaling	Parameters and Units on Display
	Relative humidity (RH) 0 ... 100 % Temperature (T) -40 ... +140 °F	RH (%) T (°F)
	Dewpoint (Td) -40 ... +140 °F Temperature (T) -40 ... +140 °F	Td (°F) T (°F)
	Enthalpy (h) -10 ... +190 BTU/lb Temperature (T) -40 ... +140 °F	h (BTU/lb) T (°F)
	Wet bulb temperature (Tw) -40 ... +140 °F Temperature (T) -40 ... +140 °F	Tw (°F) T (°F)

CHAPTER 4

MAINTENANCE

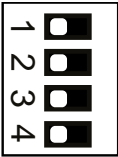
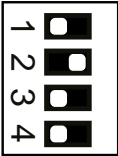
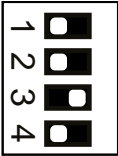
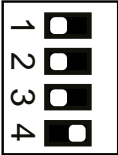
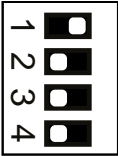
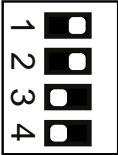
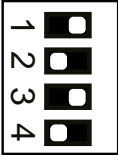
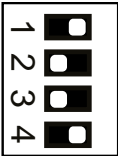
This chapter provides information that is needed in basic maintenance of HMDW80 series.

Cleaning

The body of the transmitter can be cleaned by wiping with a moistened lint-free cloth. Do not use cleaning agents or solvents, or blow pressurized air into the transmitter housing or on the filter.

NOTE

Do not attempt to clean contaminated INTERCAP[®] sensors or filters. Instead, replace them with new parts. Filters and sensors can be purchased from Vaisala. For order codes, see section Spare Parts and Accessories on page 47.

Calibration

You can verify the performance of your HMDW80 series transmitter by comparing its reading with the reading from a portable reference instrument such as the HM70 Hand-Held Humidity and Temperature Meter. For operating instructions, refer to the documentation of your reference instrument.

If the comparison indicates that the reading from the transmitter is not within specification, the transmitter may need to have its filter and sensor replaced.

Replacing the INTERCAP[®] Humidity Sensor

HMDW80 series transmitters use the Vaisala INTERCAP[®] sensor for humidity measurement. The INTERCAP[®] sensor is designed to be replaced when necessary, and does not require adjustment by the user.

Replacing the INTERCAP[®] Sensor on Models HMD82/83 and HMW88/89

REQUIRED TOOLS

- New INTERCAP[®] humidity sensor.
- New filter (always recommended when replacing the sensor).
- Duct models only: medium size crosshead screwdriver (Pozidriv).

1. Power down the transmitter.
2. Duct models only: loosen the tightening screw on the fastening flange, and pull the probe out of the duct.
3. Remove the filter to access the sensors. See Figure 20 below.
4. Pull out the old INTERCAP[®] sensor, and insert the new one.
5. Insert the new filter.
6. Duct models only: push the probe back into the duct, to the same depth where it was before. Tighten the tightening screw on the fastening flange.
7. Power up the transmitter.
8. Verify that the transmitter now provides a valid humidity reading.

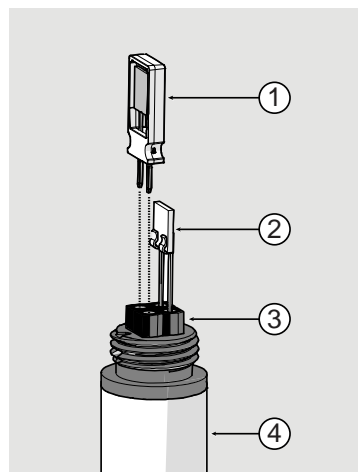

1305-024

Figure 20 Sensors on HMD82/83 and HMW88/89 Models

- 1 = Vaisala INTERCAP[®] sensor. Handle by the plastic frame.
- 2 = Temperature sensor. Do not touch or attempt to remove.
- 3 = Sensor socket.
- 4 = Transmitter probe.

Replacing the INTERCAP[®] Sensor on Wall Models HMW82/82P100/83

REQUIRED TOOLS

- New INTERCAP[®] humidity sensor.
- Small flat head screwdriver.

1. Use the screwdriver to push down on the tab on the top of the transmitter and open the transmitter cover.
2. Remove the old sensor, and insert the new one. See Figure 21 below.
3. Reconnect the cover to the mounting base.
4. Verify that the transmitter now provides a valid humidity reading.

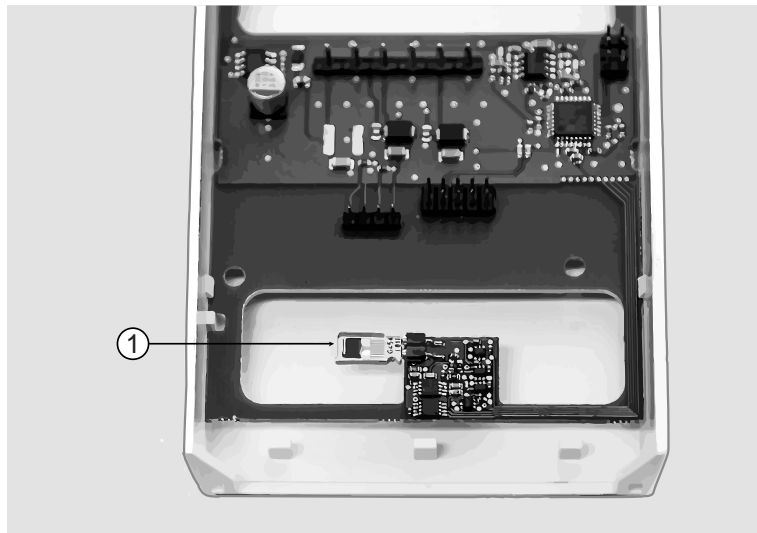

1305-018

Figure 21 INTERCAP[®] Sensor on HMW82/83 Models

Replacing the INTERCAP® Sensor on Outdoor Models HMS82/83

REQUIRED TOOLS

- New INTERCAP® humidity sensor.
- New filter (always recommended when replacing the sensor).
- Medium size crosshead screwdriver (Pozidriv)
- Flat head screwdriver
- 3 mm hex key (Allen key) for opening the radiation shield screws.
- If transmitter mounted on pole: 2.5 mm hex key for opening and tightening the set screw.

NOTE

You will need to remove the radiation shield to access the sensor, and this is difficult to do while the transmitter remains mounted on a pole or wall. The procedure below takes advantage of the detachable screw terminal to allow the cable to remain in place during the operation.

1. Power down the transmitter.
2. Open the transmitter cover and unplug the screw terminal. This allows you to leave the cable and cover at the installation site.

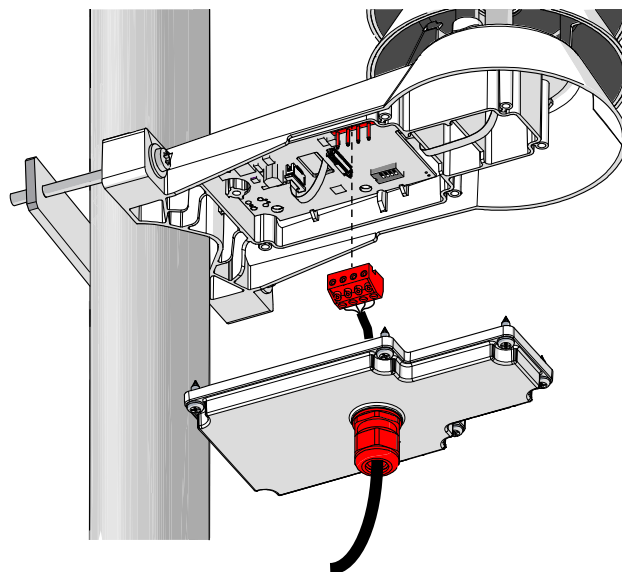

1305-019

Figure 22 Unplugging the Screw Terminal

3. Remove the transmitter from its installation point.

4. Open the two long screws that hold the radiation shield, and pull them out.

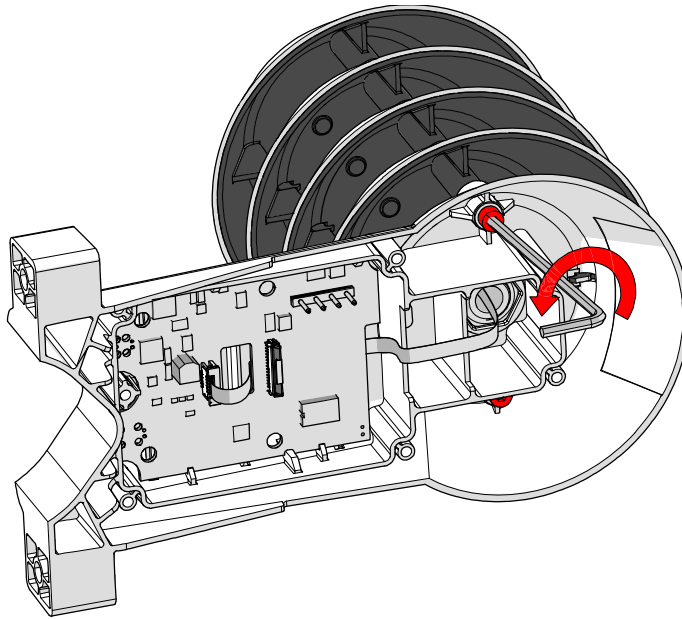

1305-020

Figure 23 Opening the Radiation Shield Screws

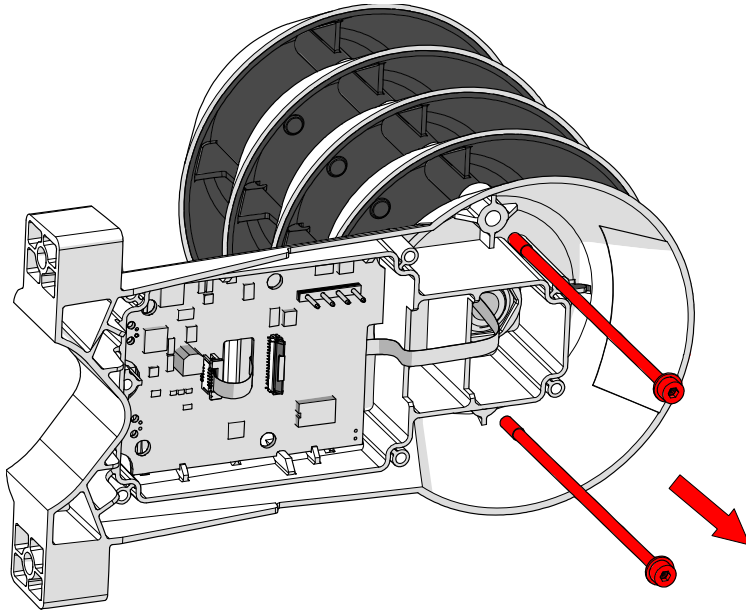

1305-021

Figure 24 Removing the Radiation Shield Screws

5. Use a flat head screwdriver to push on the visible plastic tab below the radiation shield.

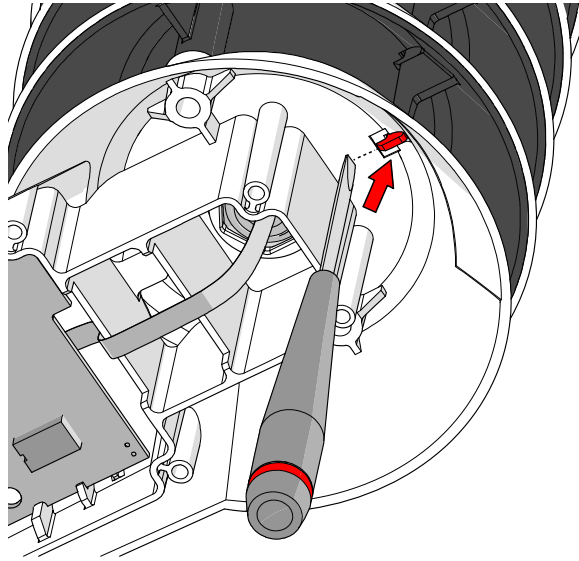

1305-022

Figure 25 Location of Locking Tab

6. Tilt the radiation shield away from the opened tab. This opens the second tab on the other side, allowing you to remove the radiation shield.

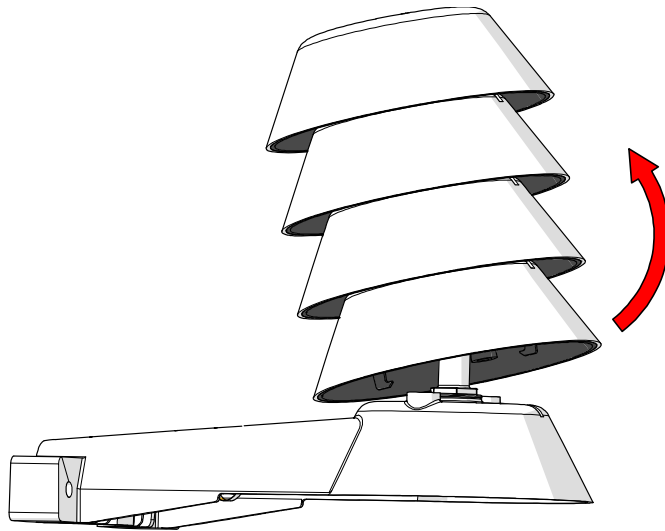

1305-023

Figure 26 Removing the Radiation Shield

7. Open the filter to expose the sensors.

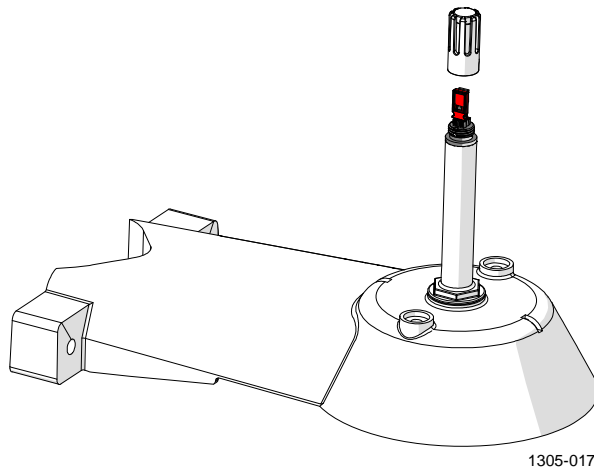

Figure 27 Filter Removed

8. Pull out the old INTERCAP® sensor, and insert the new one.

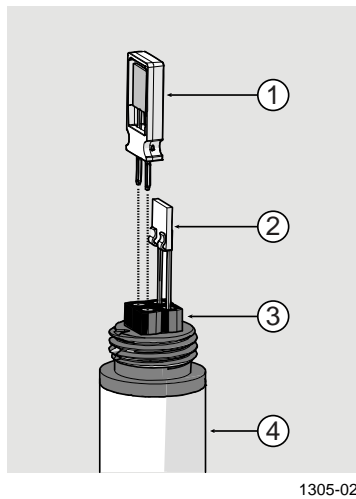

Figure 28 Sensors on HMS82/83 Models

- 1 = Vaisala INTERCAP® humidity sensor.
Handle by the plastic frame.
 - 2 = Temperature sensor. Do not touch or attempt to remove.
 - 3 = Sensor socket.
 - 4 = Transmitter probe.
9. Insert the new filter.
 10. Reassemble, remount, and reconnect the transmitter.
 11. Power up the transmitter.
 12. Verify that the transmitter now provides a valid humidity reading.

CHAPTER 5

TROUBLESHOOTING

This chapter describes possible problems, their probable causes and remedies, and provides contact information for technical support.

Problem Situations

Table 7 Possible Problem Situations and Their Remedies

Problem	Probable Cause and Remedy
Transmitter outputs an incorrect humidity reading.	<ol style="list-style-type: none">1. Models with probes: check if the yellow transport protection cap has been left over the probe. Remove it if present.2. Models with configurable output parameter: check that the desired output parameter has been selected using the DIP switches.
Temperature reading shown by the transmitter is too high.	<ol style="list-style-type: none">1. The transmitter may be installed in an unsuitable location, for example, near a heat source or in sunlight. Use a portable reference meter to check this.2. HMW82 and HMW83: Check that the transmitter is installed in proper orientation, with the arrow on the mounting base pointing up.
Current output on the temperature channel is ~24 mA.	Check that the humidity output channel is powered. Loop powered HMDW80 series models that have humidity measurement require that the humidity output channel is connected, even if only measuring temperature.
Analog output reading is unchanging and incorrect.	The analog output channel may be in an error state. See section Analog Output Error State on page 41.

Analog Output Error State

HMDW80 series transmitters set the output channel(s) into a defined error level instead of the measured result in two situations:

- Transmitter detects a measurement malfunction. This means an actual measurement problem, such as sensor damage or unsuitable environmental conditions.
- Measured value(s) are well outside the scaled output range. For a more detailed explanation, see section Analog Output Overrange Behavior on page 17.

The error level depends on the output type:

- For 0 ... 10 V output, the error level is **11 V**.
HMW83 and TMW83 are an exception to this, their error level is **0 V**.
- For 4 ... 20 mA output, the error level is **3.6 mA**.

The transmitter resumes normal operation of the analog output(s) when the cause of the error state is removed.

Error Messages on the Display

Table 8 Error Messages on the Display

Error Message	Possible Cause and Solution
INTERNAL 1 INTERNAL 2 INTERNAL 3	Internal problem with the transmitter. Restart the transmitter to see if the problem remains. Contact Vaisala technical support if unable to remove the problem.
ERROR HUM	Humidity measurement failed. Check if the humidity sensor is damaged or missing.
ERROR T	Temperature measurement failed. Check if the temperature sensor is damaged or missing.

Technical Support

For technical questions, contact the Vaisala technical support by e-mail at helpdesk@vaisala.com. Provide at least the following supporting information:

- Name and model of the product in question
- Serial number of the product
- Name and location of the installation site
- Name and contact information of a technically competent person who can provide further information on the problem.

For Vaisala Service Center contact information, see www.vaisala.com/servicecenters.

CHAPTER 6

TECHNICAL DATA

This chapter provides the technical data of the HMDW80 series.

Specifications

Table 9 Specifications for Models HMW82/83/HMW82P100 and TMW82/83

Property	Description / Value
Operating environment	
Operating temperature range	-5 ...+55 °C (+23 ... +131 °F)
Operating humidity range	0 ...100 %RH, non-condensing
Relative humidity	
Measurement range	0 ... 100 %RH
Accuracy	
Temperature range +10 ... +30 °C (+50 ... +86 °F) 30 ... 70 %RH	±3 %RH
0 ... 30 %RH, 70 ... 100 %RH	±5 %RH
Temperature range -5 ... +10 °C, +30 ... + 55 °C (+23 ... +50 °F, +86 ... +131 °F) 0 ...100 %RH	±7 %RH
Stability in typical HVAC applications	±2 %RH over 2 years
Humidity sensor	Vaisala INTERCAP [®]
Temperature	
Measurement range	-5 ...+55 °C (+23 ... +131 °F)
Accuracy	
+10 ... +30 °C (+50 °F ... +86 °F)	±0.5 °C (±0.9 °F)
-5 ... +10 °C, +30 ... +55 °C (+23 ... +50 °F, +86 ... +131°F)	±1.0 °C (±1.8 °F)
Temperature sensor	Digital temperature sensor
	HMW82P100: Pt100 Class F 0.1 IEC 60751

Table 10 Specifications for Models HMD82/83, TMD82/83, HMW88/89, HMS82/83, and TMS82

Property	Description / Value
Operating environment	
Operating temperature range	-40 ...+60 °C (-40 ... +140 °F)
Operating humidity range	0 ...100 %RH
Relative humidity	
Measurement range	0 ... 100 %RH
Accuracy	
Temperature range +10 ... +30 °C (+50 ... +86 °F)	
0 ... 90 %RH	±3 %RH
90 ... 100 %RH	±5 %RH
Temperature range -20 ... +10 °C, +30 ... +60 °C (-4 ... +50 °F, +86 ... +140 °F)	
0 ... 90 %RH	±5 %RH
90 ... 100 %RH	±7 %RH
Temperature range -40 ... -20 °C (-40 ... -4 °F)	
0 ... 100 %RH	±7 %RH
Stability in typical HVAC applications	±2 %RH over 2 years
Humidity sensor	Vaisala INTERCAP®
Temperature	
Measurement range	-40 ...+60 °C (-40 ... +140 °F)
Accuracy	
At +20 °C (+68 °F)	±0.3 °C (±0.54 °F)
Temperature dependence	±0.01 °C/°C
Temperature sensor	Pt1000 RTD Class F0.1 IEC 60751
Calculated parameters	
Measurement range for dewpoint temperature and wet bulb temperature	-40 ...+60 °C (-40 ... +140 °F)
Measurement range for enthalpy	-40...460 kJ/kg (-10...+190 BTU/lb)
Accuracy of the calculated parameters should be calculated at the actual condition based on the relative humidity and temperature specification.	
Accuracy at +20 °C (+68 °F) and 80 %RH:	
Dewpoint	±0.9 °C (1.6 °F)
Wet bulb temperature	±0.7 °C (1.3 °F)
Enthalpy	±2kJ/kg (0.9 BTU/lb)

Table 11 Specifications for Models HMD82/83D, HMW88/89D, and TMW88

Property	Description / Value
Operating environment	
Operating temperature range	-5 ... +60 °C (+23 ... +140 °F)
Operating humidity range	0...100 %RH, non-condensing
Relative humidity	
Measurement range	0 ... 100 %RH
Accuracy	
Temperature range	
+10 ... +30 °C (+50 ... +86 °F)	
0 ... 90 %RH	±3 %RH
90 ... 100 %RH	±5 %RH
Temperature range	
-5 ... +10 °C, +30 ... +60 °C	
(+23 ... +50 °F, +86 ... +140 °F)	
0 ... 90 %RH	±5 %RH
90 ... 100 %RH	±7 %RH
Stability in typical HVAC applications	±2 %RH over 2 years
Humidity sensor	Vaisala INTERCAP®
Temperature	
Measurement range	
(Analog output scaling)	-40 ... +60 °C (-40 ... +140 °F)
Operating temperature range of the display	-5 ... +60 °C (+23 ... +140 °F)
Accuracy	
At +20 °C (+68 °F)	±0.3 °C (±0.54 °F)
Temperature dependence	±0.01 °C/°C
Temperature sensor	Pt1000 RTD Class F0.1 IEC 60751
Calculated parameters	
Measurement range for dewpoint temperature and wet bulb temperature	-40 ...+60 °C (-40 ... +140 °F)
Measurement range for enthalpy	-40...460 kJ/kg (-10...+190 BTU/lb)
Accuracy of the calculated parameters should be calculated at the actual condition based on the relative humidity and temperature specification.	
Accuracy at +20 °C (+68 °F) and 80 %RH:	
Dewpoint	±0.9 °C (1.6 °F)
Wet bulb temperature	±0.7 °C (1.3 °F)
Enthalpy	±2kJ/kg (0.9 BTU/lb)

Table 12 Operating Environment (All Models)

Property	Description / Value
Operating environment	See model specifications
Maximum wind/flow speed	30 m/s
Storage temperature	-40 ... +60 °C (-40 ... +140 °F)
Electromagnetic compliance	EN61326-1, industrial environment

Table 13 Inputs and Outputs

Property	Description / Value
Current output models (2-wire) Outputs Loop resistance Supply voltage	4 ... 20 mA, loop powered 0 ... 600 Ω 20 ... 28 VDC at 600 Ω load 10 ... 28 VDC at 0 Ω load
Voltage output models (3-wire) Outputs Load resistance Supply voltage Current consumption	0 ... 10 V 10 kΩ min 18 ... 35 VDC 24 VAC ±20 % 50/60 Hz 10 mA on DC power 30 mA on AC power

Table 14 Mechanics

Property	Description / Value
Max. wire size	1.5 mm ² (AWG 16)
Standard housing color	White (RAL9003)
Housing material HMW82/83, TMW82/83 HMW88/89(D), HMD82/83(D), TMD82/83, HMS82/83	ABS/PC (UL-V0 approved) PC + 10%GF (UL-V0 approved)

Spare Parts and Accessories



Information on spare parts, accessories, and calibration products is available online at www.vaisala.com and store.vaisala.com.

Table 15 HMDW80 Series Spare Parts and Accessories

Description	HMD82/83	TMD82/83	HMW82/83	HMW82P100	TMW82/83	HMW88/89	TMW88	HMS82/83	TMS82	Item Code
Sensors										
Vaisala INTERCAP® humidity sensor, 1 piece	•		•	•		•		•		15778HM
Vaisala INTERCAP® humidity sensor, 10 pcs	•		•	•		•		•		INTERCAPSET-10PCS
Sensor protection										
PTFE membrane filter	•	•						•	•	ASM210856SP
PTFE filter						•	•			DRW239993SP
Accessories and Spare Parts										
Fastening flange assembly (screws included)	•	•								ASM210771SP
Fastening set for HMS80								•	•	237805
Cable gland with O-ring	•	•				•	•	•	•	CABLEGLANDORING
Lid assembly with window for display (screws included)	•	•				•	•			ASM210793SP
Conduit fitting + O-ring (M16x1.5 / NPT1/2 Inch)	•	•				•	•	•	•	210675SP
Conduit fitting + O-ring (M16x1.5 / PG9, RE-MS)	•	•				•	•	•	•	210674SP
Terminal block, blue	•	•				•	•	•	•	236620SP

• = Part is compatible



www.vaisala.com

